

East Anglia Hub – SNS 2023

Mike Somerville
Project Controls Manager
ScottishPower Renewables

May 2023

SPR Offshore Pipeline - UK & Ireland

A diverse UK & Ireland pipeline at various stages of development...

- Origination
- Development
- Pre-FID
- Operational

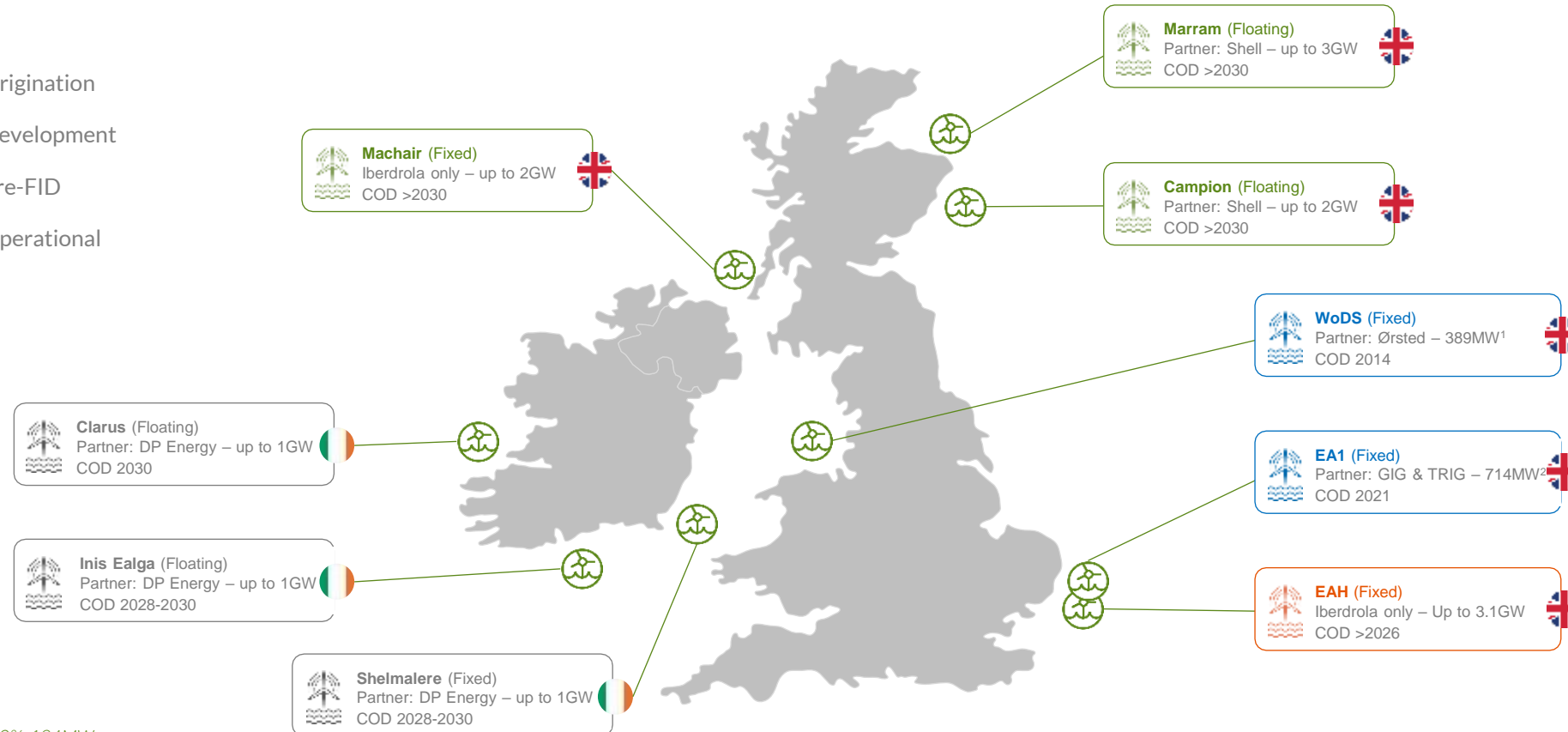

¹ Iberdrola stake 50%: 194MW

² Iberdrola stake 60%: 428MW

³ Full project capacities, not adjusted for Iberdrola stakes noted above

...with 4.2GW³ expected to be operational by 2027.

East Anglia Hub - Overview

6% of UK Government's 50GW by 2030 target, c3GW offshore wind pipeline



EA3

- Consented with 1400Mw
- c95 14.7Mw WTG's
- HVDC grid connection
- CFD auction round 4 success Q4 2022
- Onshore construction commenced July 2022
- Offshore construction 2024, COD 2026



EA2

- Consented for a maximum of 75 WTG's
- c940Mw using 14.7MW WTG
- AC grid connection
- Preparing for Qualification & Bid in summer 2023



EA1N

- Consented for a maximum of 67 WTG's
- c600Mw using 14.7MW WTG
- AC grid connection

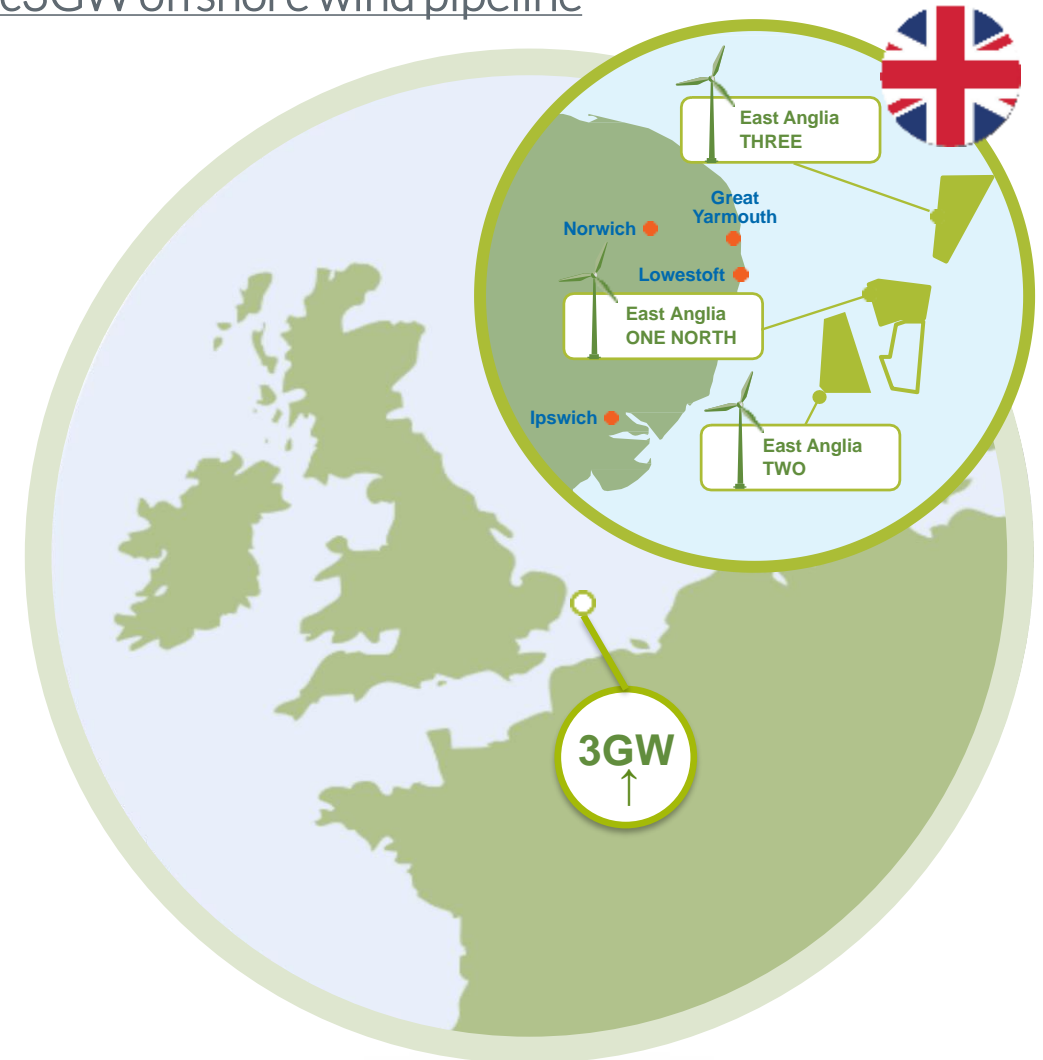

East Anglia Hub – EA3



East Anglia 3 Focus



East Anglia THREE – CfD Auction round 4 Success



Auction Round 4 Success

- CfD @ @ £37.35 /MWh for 1.37GW
- Achieved Q3 2022



Organisational Ramp Up

- Project Team grown to 150+ resources
- Locations: Glasgow, London, Lowestoft, Madrid



Design Development & Freeze

- Windfarm Layout & Sequencing Development
- Foundation Design Freeze

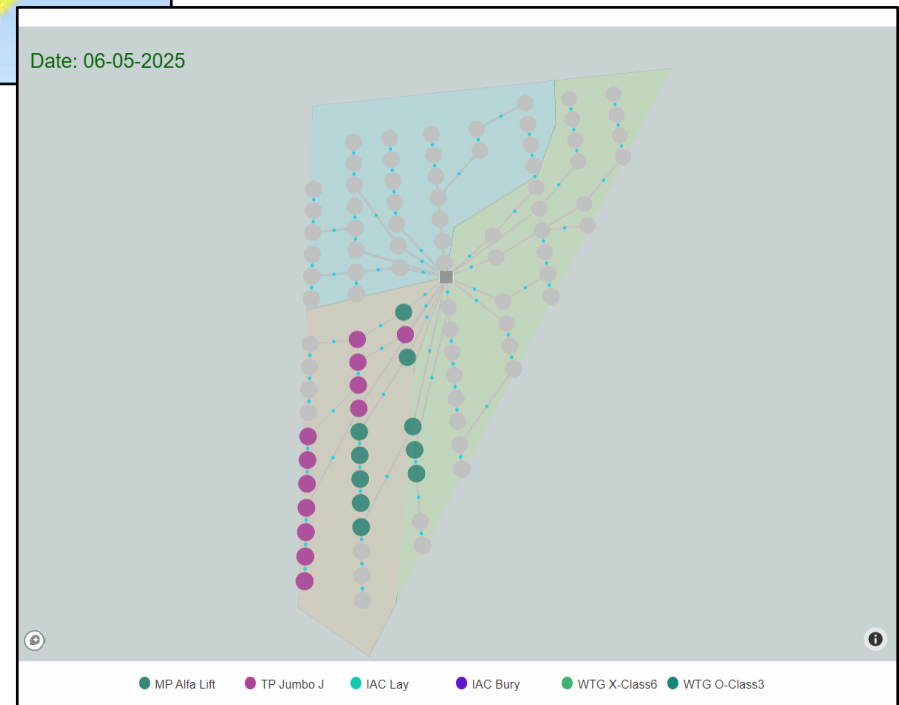
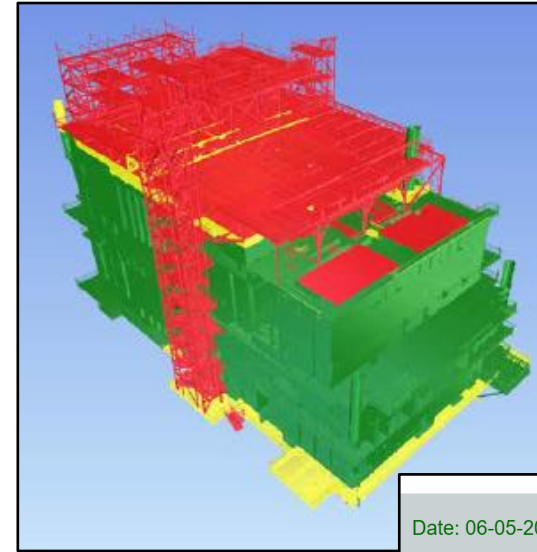

East Anglia Three – Secured Supply Chain



East Anglia Three – Secured Supply Chain

seaway⁷

Scope	T&I
Status	PBSCA
Location	Lowestoft, Aberdeen (UK) & Zoetermeer (NL)

CADELER

Scope	WTG Vessel Supply
Status	Full Contract
Location	Copenhagen (Denmark)

Navantia **WINDAR**
haizea windgroup

Scope	Foundation Supply
Status	Full Contracts
Location	Haizea (Bilbao), Windar (Aviles) & Navantia (Fene)



SIEMENS Gamesa
RENEWABLE ENERGY

Scope	WTG Supply
Status	Full Contract
Location	Hull (UK) & Hamburg (Germany)

NKT

Scope	HVDC Export Cable
Status	Full Contract
Location	Sweden & Cologne (Germany)

SIEMENS Energy **AkerSolutions**

Scope	HVDC Converter Station
Status	Full contract
Location	SE: Manchester (UK) & Nureng (Germany) Aker: Norway & Romania

East Anglia THREE – Onshore Converter Station Progress



East Anglia 3 – High Level Programme



PROGRAMME MILESTONES

2023

UXO inspections & ID Offshore
 Detailed Design Completions
 Foundation fabrication
 HVDC fabrication
 Extensive onshore construction

2024

Manufacturing continues
 Site clearances – UXO/boulders

2025

Offshore construction commences
 Foundations
 HVDC platform
 Arrays
 Scour protection

2026

WTG Installation Offshore
 Commercial Operation

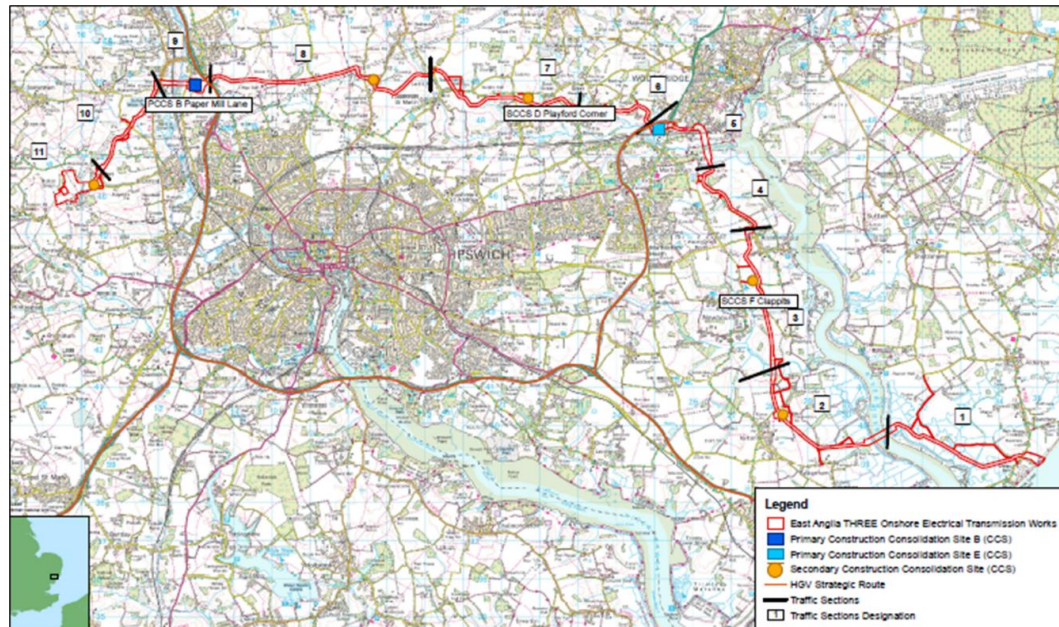

East Anglia Hub – EA1N/2



East Anglia 1N/2 Focus



East Anglia 1N/2 – Progress



Successes

- Achieved consent
- Supply Chain Plan Accepted
- Focusing on AR5
- Continued Supply Chain Engagement
- Design optimisation Continuing
- 1st Judicial review outcome
- Habitat Compensation Measures

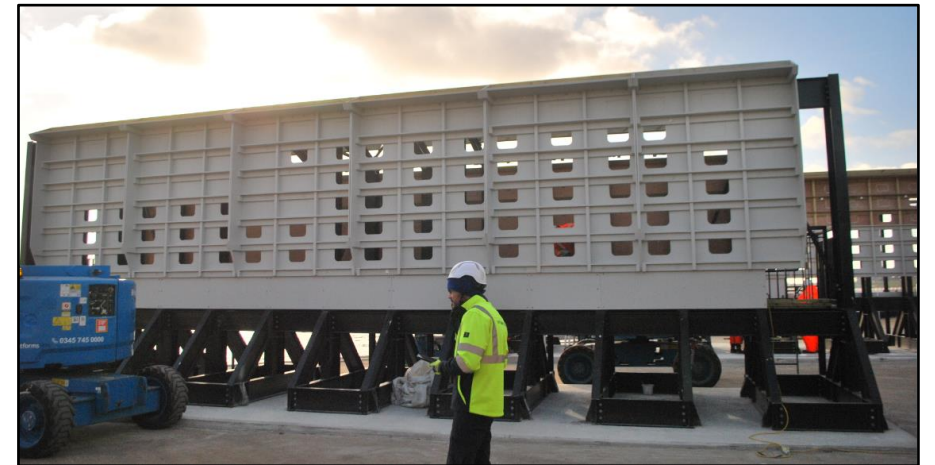
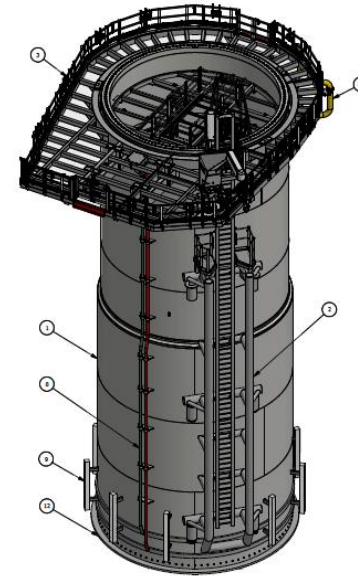

Next 12 Months Focus

- EA3 Fabrication (HVDC, Found, WTG, ExCable)
- Onshore Construction Continuation

- AR5 Auction Success
- Secure Supply Chain

- Continue to Recruit & Grow team
- Continue to Grow in Region and on EA1 Success

East Anglia Hub

The combined capacity of our East Anglia Hub projects could generate enough clean, green electricity to power more than every home in the East of England.



Up to
3GW
 cleaner energy

Up to
£6.5bn
 overall investment

Up to
2.7m
 homes powered

better future, quicker



[@SPRenewables](#)



[SPREastAnglia.co.uk](https://www.spreastanglia.co.uk)



sproffshoresupplychain@scottishpower.com



[ScottishPower.jobs](https://www.scottishpower.jobs)

May 2023

Thank you

May 2023

